



SIMPSON

Strong-Tie

®

Connectors for Cold-Formed Steel Curtain-Wall Construction

Code Listed: IAPMO ES ER-238

(800) 999-5099
www.strongtie.com

Innovative Solutions for Curtain-Wall Framing

Simpson Strong-Tie is committed to providing an expanded product range for cold-formed steel applications, and has developed a line of connectors for use with curtain-wall steel stud framing. Curtain-wall projects require a variety of connectors that provide a load path from the curtain wall to the primary structure for wind loads, seismic loads and dead loads. Slide-clip connectors enable the structural building frame to deflect independently of the curtain-wall system. Fixed-clip connectors support the dead load of a curtain wall from the structural frame. Fixed clips have the added benefit of providing connector solutions for load-bearing walls and for roof systems utilizing steel trusses and rafters.

Our connectors for curtain-wall construction accommodate many different bypass framing applications in a variety of stand-off conditions. We also offer connectors for head-of-wall and strut applications.

Tailored To Your Design

All our standard slide clips accommodate 1" of both upward and downward movement, equivalent to an L/360 live-load deflection for a 30' span. Our standard clips also accommodate stand-offs as large as 12 1/4". For deflections greater than 1", or stand-offs greater than 12 1/4", Simpson Strong-Tie can provide custom clips to suit most framing needs (see page 12). Our SCB and SCW slide-clip connectors can be manufactured for 1 3/8" of both upward and downward movement. Please call us for information about this option.

Complete, Tested Solutions

Designers of curtain walls will often know the capacity of a connector, but since the capacity does not take into account the way in which the connector is anchored to the supporting structure, the Designer must then manually calculate this important aspect of the connection design. These calculations are complicated by considerations of eccentric and prying forces that often exist but are difficult to predict. Through comprehensive testing Simpson Strong-Tie provides total, code listed connector solutions. Our testing extends from the capacity of the connector and its attachment to the framing, to the anchorage of the connector to the primary structure. By providing complete data on the entire connection system, we save the Designer time and ensure that all forces, including eccentric and prying forces, are adequately considered.

As with all Simpson Strong-Tie® products, our slide-clip and fixed-clip connectors for curtain-wall steel stud framing carry our promise of quality and performance, and are backed by prompt, knowledgeable service.

This information is subject to change. For the most up-to-date product information please refer to www.strongtie.com/cfs. For special orders, please call (800) 999-5099.

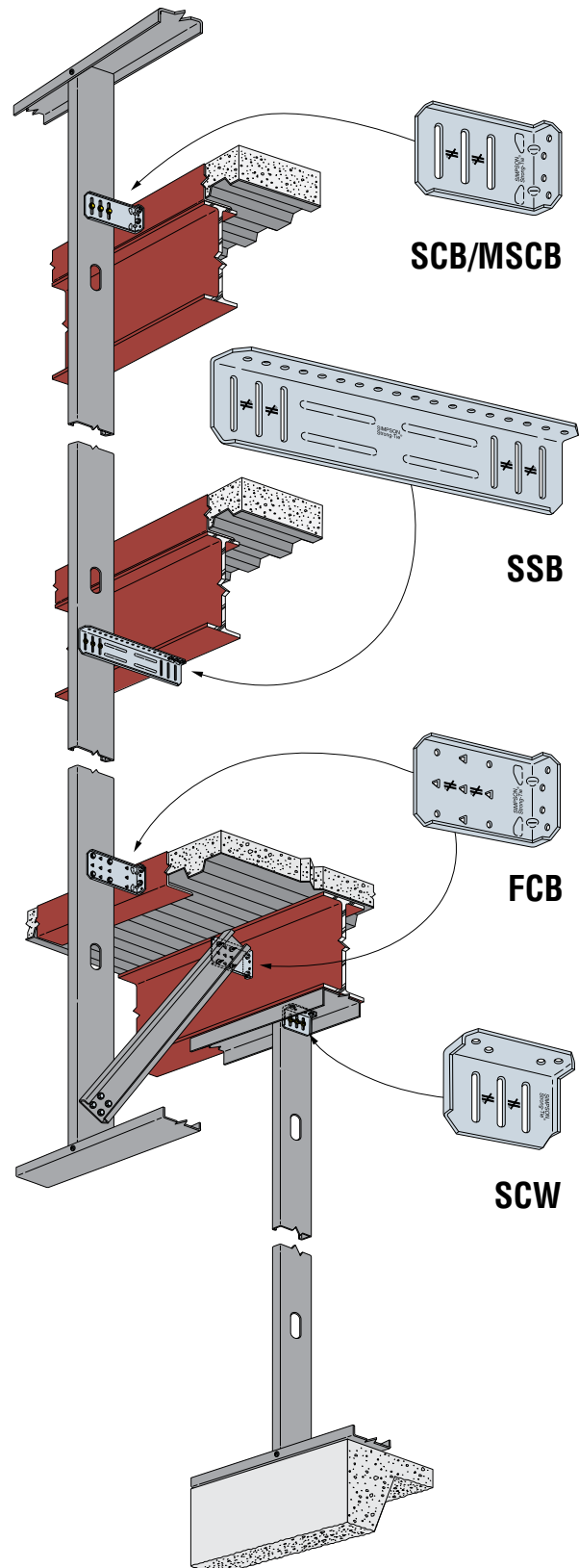

Code Listed: IAPMO ES ER-238
(except MSCB)

General Notes

General Notes for Allowable Connector Load Tables

1. Allowable loads are for use when utilizing the traditional Allowable Stress Design methodology. Contact Simpson Strong-Tie for LRFD loads.
2. Allowable loads are based on cold-formed steel members with a minimum yield strength, F_y , of 33 ksi and tensile strength, F_u , of 45 ksi for 43 mils (18 ga.) and thinner, and a minimum yield strength of 50 ksi and tensile strength of 65 ksi for 54 mils (16 ga.) and thicker.
3. The tabulated values for 54 mil (16 ga.) are applicable for framing members thicker than 54 mil (16 ga.) with a minimum yield strength of 50 ksi and tensile strength of 65 ksi.
4. Allowable loads for the SCB/MSCB, SCW and SSB connectors are based on #14 shouldered screws (provided with connectors) installed in the center of the slots.
5. Allowable loads may not be increased for wind or seismic load.
6. Clips do not replace stud lateral or stability bracing. Design of bracing is the responsibility of the Designer.
7. It is the responsibility of the Designer to verify the adequacy of the stud. Allowable loads are based on clips installed an adequate distance away from penetrations, notches, ends of studs and other conditions that may affect the clip performance.
8. Industry studies show that hardened fasteners can experience performance problems in wet or corrosive environments. Accordingly, use these products in dry and non-corrosive environments only.

General Notes for Allowable Anchorage Load Tables

1. Allowable loads are for use when utilizing the traditional Allowable Stress Design methodology. Contact Simpson Strong-Tie for LRFD loads.
2. Allowable loads may not be increased for wind or seismic load.
3. Allowable loads for #12-14 self-drilling screws are based on a minimum nominal shear strength, P_{ss} , of 2485 lbs., and nominal tension strength, P_{ts} , of 2595 lbs.
4. Allowable loads for #12-14 self-drilling screws and PDPT powder-actuated fasteners are based on installation in minimum $\frac{3}{16}$ " thick structural steel with $F_y = 36$ ksi. It is the responsibility of the Designer to select the proper length fasteners based on the installation.
5. Allowable loads for Simpson Strong-Tie® Titen® screws are based on installation in concrete with a minimum $f'_c = 2500$ psi and a maximum $f'_c = 4000$ psi. Reference the current *Anchoring and Fastening Systems for Concrete and Masonry* catalog and its Addendum for more information about Titen screws.
6. Allowable loads for welded connections require E70XX electrodes with a minimum throat size equal to the clip thickness. Welding shall be in compliance with AWS D1.3. Welding galvanized steel may produce harmful fumes; follow proper welding procedures and precautions.
7. Allowable loads are for anchorage only. It is the responsibility of the Designer to verify the strength and stability of the structure for the loads imposed by the cold-formed steel framing connections.
8. Industry studies show that hardened fasteners can experience performance problems in wet or corrosive environments. Accordingly, use these products in dry and non-corrosive environments only.

When It Comes to Fastening Curtain-Wall Clips with P.A.T. or Concrete Screws, We've Got You Covered

In addition to self-drilling screws and welding, Simpson Strong-Tie® connectors for curtain-wall construction are designed to be fastened with our powder-actuated fasteners and concrete screws.

PDPAT Tophat Fasteners

The PDPAT powder-actuated pins called out in this flier are part of the Simpson Strong-Tie jobsite-proven P.A.T. system. These fasteners are pins with .300" heads and a 0.157" shank diameter and feature a "tophat" which ensures adequate clamping force and consistent installations. They are suitable for use with the majority of Simpson Strong-Tie powder-actuated tools as well as tools from other popular manufacturers.



Titen® Concrete and Masonry Screws

Titen screws are heat-treated fasteners designed to attach all types of fixtures to concrete and masonry. They install easily in a pre-drilled hole and include a drill bit in each box. Available in both hex and flat head styles, the hex-head version is required for Simpson Strong-Tie connectors for curtain-wall construction.



For more information on our full line of anchoring and fastening systems for concrete and masonry, visit www.strongtie.com or reference our *Anchoring and Fastening Systems for Concrete and Masonry* catalog.



SCB/MSCB Bypass Framing Slide-Clip Connector

The SCB/MSCB slide-clip connectors are high-performance connectors for bypass framing applications designed to reduce design time and overall installed cost. Various anchorage methods have been tested, and the resulting allowable loads eliminate the need to design connector anchorage. The SCB/MSCB can accommodate applications that typically require two parts with a single connector, reducing material and labor cost. These connectors are manufactured in five different lengths to accommodate a variety of stand-off conditions and steel-stud sizes.

FEATURES:

- Provides a full 1" of both upward and downward movement
- SCB clips that allow 1 3/8" of upward and downward movement are available by special order. Contact Simpson Strong-Tie for details.
- The precision-manufactured shouldered screws provided with the SCB/MSCB connector are designed to prevent overdriving and to ensure the clip functions properly
- Strategically placed stiffeners, embossments and anchor holes maximize connector performance
- Simpson Strong-Tie® "No-Equal" stamps mark the center of the slots to help ensure correct shouldered-screw placement

MATERIAL: SCB – 54 mil (16 ga.); MSCB – 68 mil (14 ga.)

FINISH: Galvanized (G90)

INSTALLATION:

- Use the specified type and number of anchors.
- Use the specified number of #14 shouldered screws (included). Install shouldered screws in the slots adjacent to the "No-Equal" stamp.
- Use a maximum of 1 screw per slot.

CODES: SCB—IAPMO UES ER-238

MSCB—Testing performed in accordance with ICC-ES AC261

Ordering Information:

SCB43.5-KT contains:

- 25 connectors
- (55) #14 shouldered screws

SCB45.5-KT, MSCB45.5-KT, SCB47.5-KT, MSCB47.5-KT, SCB49.5-KT, and SCB411.5-KT contain:

- 25 connectors
- (83) #14 shouldered screws

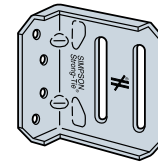

SCB43.5

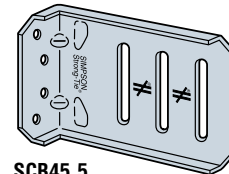

SCB45.5
(MSCB45.5 similar)

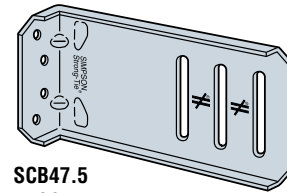

SCB47.5
(MSCB47.5 similar)

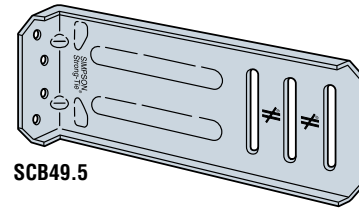

SCB49.5

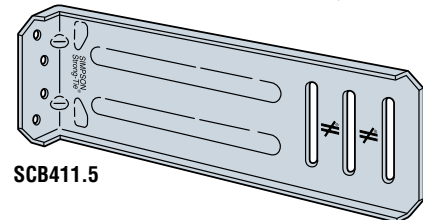

SCB411.5

U.S. Patent Pending

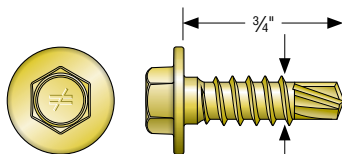

#14 Shouldered Screw

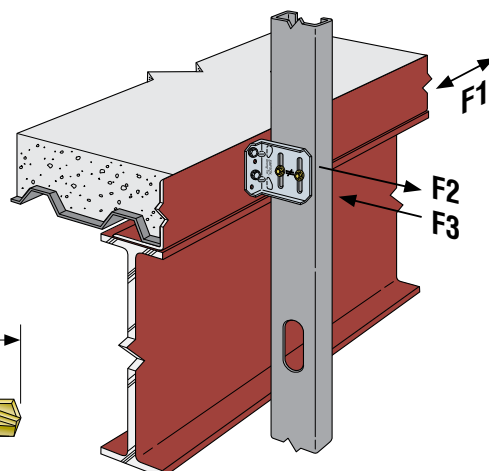

Typical SCB/MSCB Installation

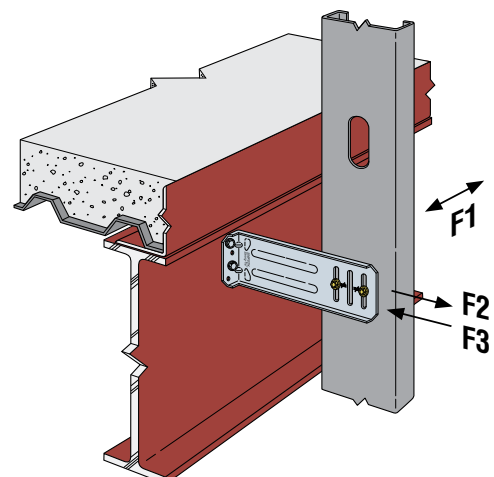

SCB/MSCB Installation at Fascia Beam

SCB/MSCB Bypass Framing Slide-Clip Connector

SCB / MSCB Allowable Connector Loads (lbs.)

Model No.	Connector Material Thickness mil (ga.)	L (in.)	No. of #14 Shouldered Screws	Stud Thickness											
				33 mil (20 ga.)			43 mil (18 ga.)			54 mil (16 ga.)			68 mil (14 ga.)		
				F1 ^{4,5}	F2 ³	F3 ³	F1 ^{4,5}	F2 ³	F3 ³	F1 ^{4,5}	F2 ³	F3 ³	F1 ^{4,5}	F2 ³	F3 ³
SCB43.5	54 (16)	3½	2	100	520	520	155	610	690	185	760	975	185	760	975
SCB45.5	54 (16)	5½	2 ²	75	490	520	85	610	690	85	760	975	85	760	975
			3	120	675	675	140	895	1000	140	990	1260	140	990	1260
NEW MSCB45.5	68 (14)	5½	2 ²	75	490	520	120	780	690	135	1055	1200	135	1195	1475
			3	120	675	675	185	1070	1000	225	1220	1930	225	1365	1930
SCB47.5	54 (16)	7½	2 ²	55	490	520	55	610	690	55	760	945	55	760	945
			3	70	675	675	70	895	1000	70	990	1260	70	990	1260
NEW MSCB47.5	68 (14)	7½	2 ²	70	490	520	75	780	690	85	1055	1200	85	1195	1475
			3	90	675	675	90	1070	1000	110	1220	1930	110	1365	1930
SCB49.5	54 (16)	9½	2 ²	40	490	520	40	690	690	40	760	945	40	760	945
			3	45	675	675	45	895	1000	45	990	1260	45	990	1260
SCB411.5	54 (16)	11½	2 ²	30	490	520	30	690	690	30	990	920	30	990	920
			3	35	675	675	35	860	1000	35	990	1260	35	990	1260

- For additional important information, see General Notes for Allowable Connector Load Tables on page 3.
- When the SCB or MSCB connector is used with 2 shouldered screws, the screws may be installed in any 2 slots.
- Allowable loads are based on clips installed with (4) #12-14 screws in the anchor leg. For other anchorage installations, the capacity of the connection system will be the minimum of the tabulated value and the allowable load from the SCB / MSCB Allowable Anchorage Loads table below.
- Anchorage to the supporting structure using welds or a minimum of (2) #12-14 self-drilling screws is required.
- Allowable loads are based on in-planes loads applied to the stud fasteners that are nearest the support with complete rotational restraint at the studs. For a more extensive treatment of in-plane loads please refer to Simpson Strong-Tie Engineering Letter L-CF-CWCF1DIR14.

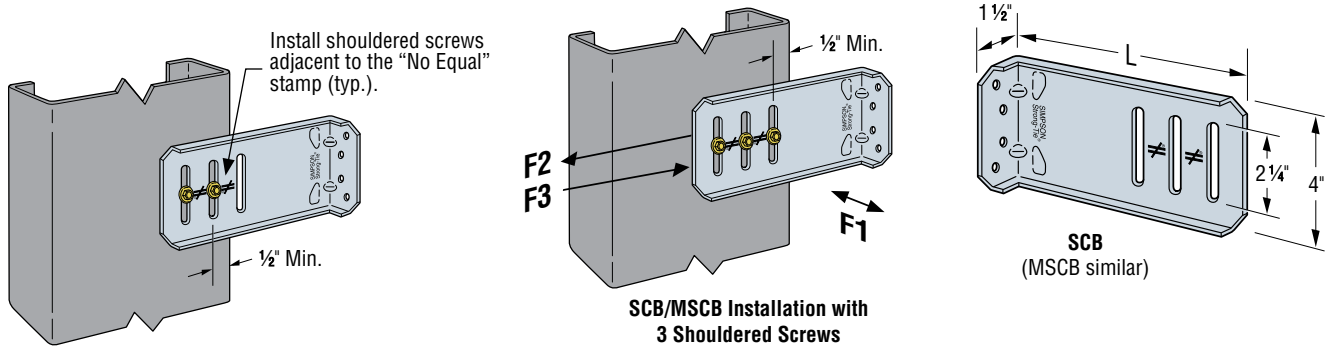

SCB/MSCB Installation with 2 Shouldered Screws

SCB/MSCB Installation with 3 Shouldered Screws

SCB / MSCB Allowable Anchorage Loads (lbs.)

Anchorage Type	No. of Anchors	Allowable Loads F2 and F3 (SCB)	Allowable Loads F2 and F3 (MSCB)
#12-14 Self-Drilling Screws	2	795	795
	3	1120	1365
	4	1260	1540
Simpson Strong-Tie® 0.145" PDPT or 0.157" PDPAT	2	280	280
	3	390	390
Powder-Actuated Fasteners	4	555	555
	2	380	380
Simpson Strong-Tie® Titen® Hex-Head Screws	3	445	445
	4	510	510
Welded	Hard side: 2"	1260	1540
	Free side: 1"		

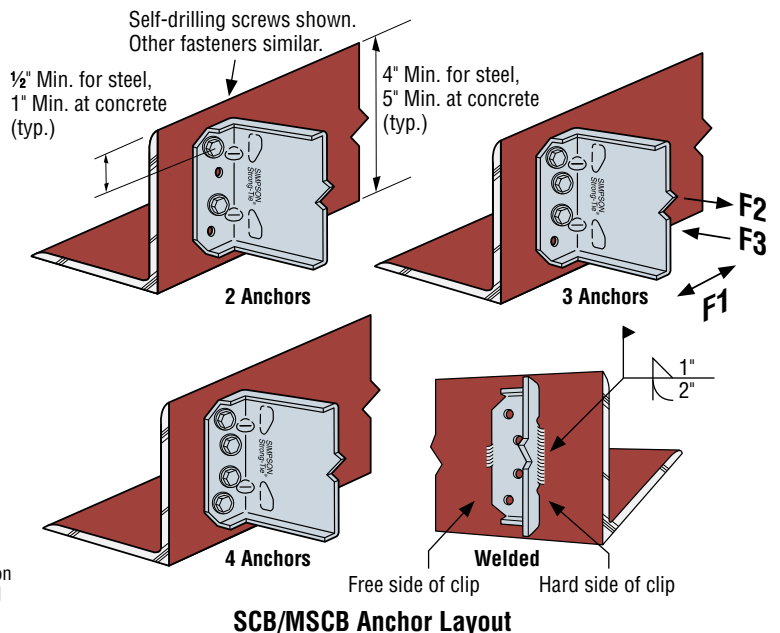

SCB/MSCB Anchor Layout

- For additional important information, see General Notes for Allowable Anchorage Load Tables on page 3.
- Allowable loads are for clip anchorage only. The capacity of the connection system will be the minimum of the tabulated value and the allowable load from the SCB / MSCB Allowable Connector Loads table above.



SCW Head-of-Wall Slide-Clip Connector

SCW slide-clip connectors are primarily used in head-of-wall applications that require vertical movement relative to the structure. The connector can also be used to strengthen window and door jambs for projects that utilize slip-track.

FEATURES:

- Provides a full 1" of both upward and downward movement
- Clips that allow 1 3/8" of upward and downward movement are available by special order. Contact Simpson Strong-Tie for details
- The precision-manufactured shouldered screws provided with the SCW connector are designed to prevent overdriving and to ensure the clip functions properly
- Anchor holes located to maximize performance
- Simpson Strong-Tie® “No-Equal” stamps mark the center of the slots to help ensure correct shouldered-screw placement

MATERIAL: 54 mil (16 ga.)

FINISH: Galvanized (G90)

INSTALLATION:

- Use the specified type and number of anchors.
- Use the specified number of #14 shouldered screws (included). Install shouldered screws in the slots adjacent to the “No-Equal” stamp.
- Use a maximum of 1 screw per slot.

CODES: IAPMO ES ER-238

Ordering Information:

SCW3.25-KT contain:

- Box of 25 connectors
- 55 shouldered screws

SCW5.5-KT contain:

- Box of 25 connectors
- 83 shouldered screws

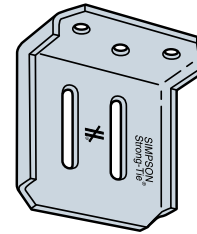

SCW3.25

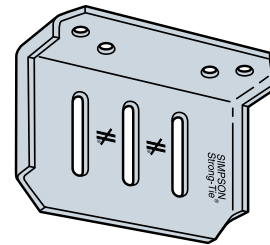

SCW5.5

U.S. Patent Pending

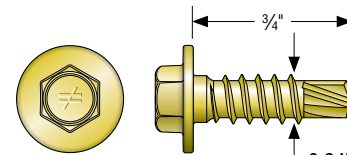

#14 Shouldered Screw

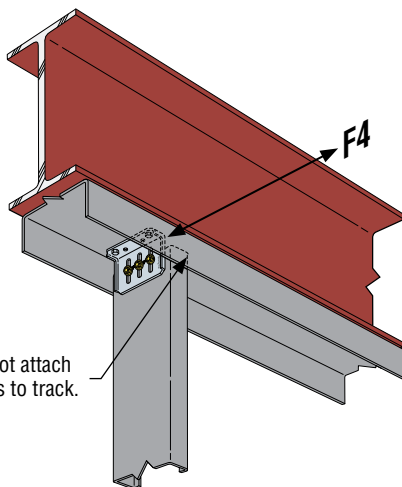

Typical SCW Installation at Stud

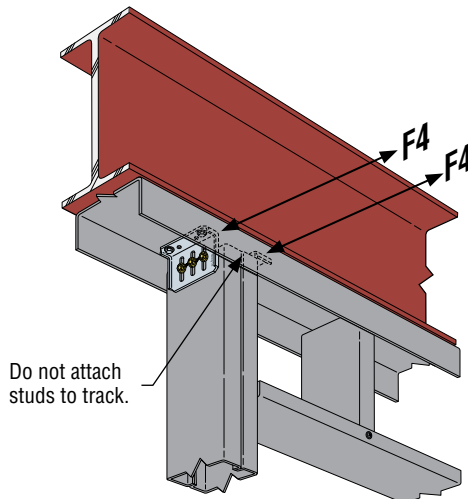

Typical SCW Installation at Window or Door Jamb

SCW Head-of-Wall Slide-Clip Connector

SCW Allowable Connector Loads (lbs.)

Model No.	Connector Material Thickness mil (ga.)	W (in.)	No. of #14 Shouldered Screws	Stud Thickness		
				33 mil (20 ga.)	43 mil (18 ga.)	54 mil (16 ga.)
SCW3.25	54 (16)	3 1/4	2	F4	F4	F4
SCW5.5	54 (16)	5 1/2	2 ²	455	630	995
			3	455	630	1220

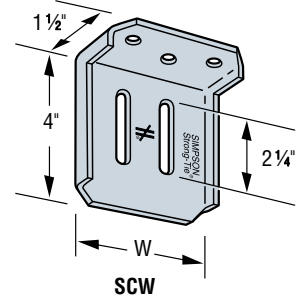

- For additional important information, see General Notes for Allowable Connector Load Tables on page 3.
- When the SCW5.5 connector is used with 2 shouldered screws, install screws in the outermost slots.
- Allowable loads are based on clips installed with all holes in the anchor leg filled with #12-14 screws. For other anchorage installations, the capacity of the connection system will be the minimum of the tabulated value and the allowable load from the SCW Allowable Anchorage Loads table below.

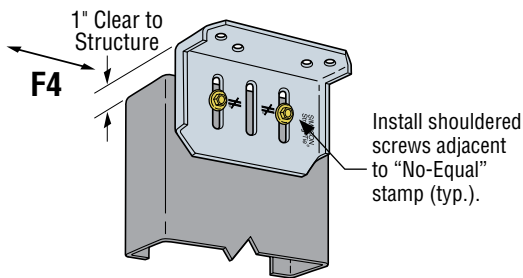

SCW5.5 Installation with 2 Shouldered Screws
(3 shouldered screws and SCW3.25 similar)

SCW Allowable Anchorage Loads (lbs.)

Model No.	Anchorage Type	No. of Anchors	Allowable Loads F4
SCW3.25	#12-14 Self-Drilling Screws	2	640
		3	755
	Simpson Strong-Tie® 0.145" PDPT or 0.157" PDPAT Powder-Actuated Fasteners	3	560
SCW5.5	#12-14 Self-Drilling screws	2	1200
		4	1220
	Simpson Strong-Tie® 0.145" PDPT or 0.157" PDPAT Powder-Actuated Fasteners	2	920
		4	1220

- For additional important information, see General Notes for Allowable Anchorage Load Tables on page 3.
- Allowable loads are for clip anchorage only. The capacity of the connection system will be the minimum of the tabulated value and the allowable load from the SCW Allowable Connector Loads table above.

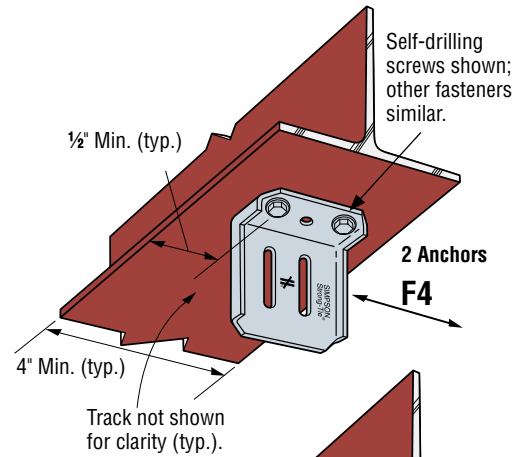

SCW3.25 Anchor Layout

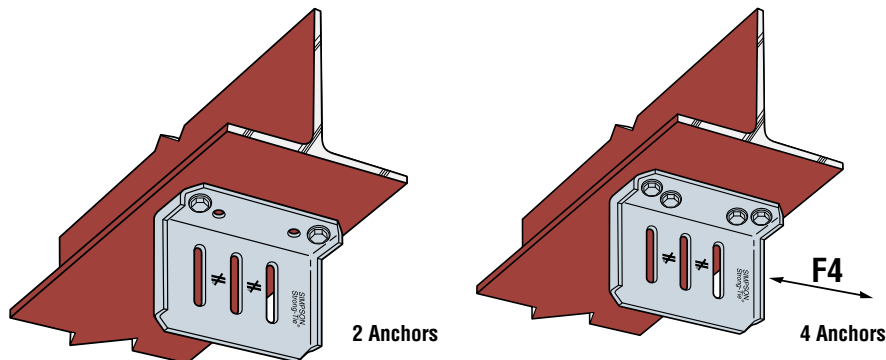

SCW5.5 Anchor Layout

SSB Bypass Framing Slide-Clip Strut Connector

The SSB bypass framing slide clip is a versatile strut connector that is commonly used at the bottom of a steel beam to accommodate large stand-off conditions.

FEATURES:

- Provides a full 1" of both upward and downward movement
- Anchor holes are positioned along the entire length of the part, and slots are located at each end so that lefts and rights are not required
- Embossments and stiffeners increase axial strength
- The precision-manufactured shouldered screws provided with the SSB connector are designed to prevent overdriving and to ensure the clip functions properly
- Simpson Strong-Tie® "No-Equal" stamps mark the center of the slots to help ensure correct shouldered-screw placement

MATERIAL: 54 mil (16 ga.)

FINISH: Galvanized (G90)

INSTALLATION:

- Use the specified type and number of anchors.
- Use the specified number of #14 shouldered screws (included). Install shouldered screws in the slots adjacent to the "No-Equal" stamp.
- Use a maximum of 1 screw per slot.

CODES: IAPMO ES ER-238

Ordering Information:

SSB3.518-KT contain:

- Box of 25 connectors
- 83 shouldered screws

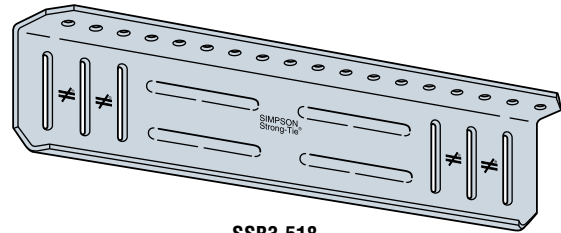

SSB3.518

U.S. Patent Pending

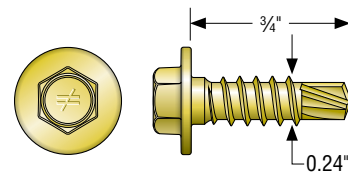

#14 Shouldered Screw

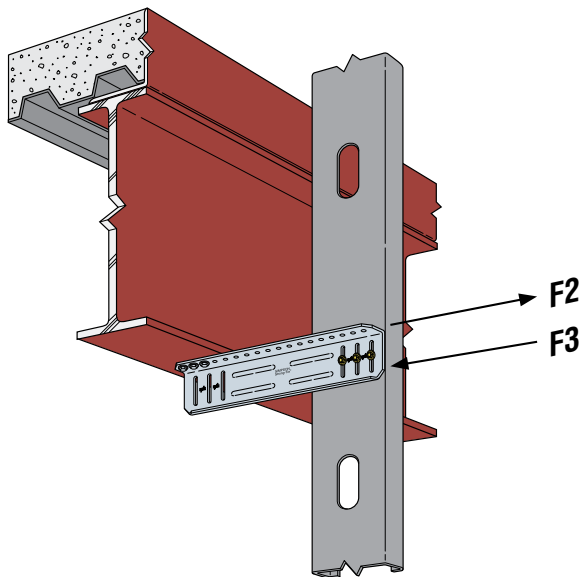

Typical SSB3.518 Installation

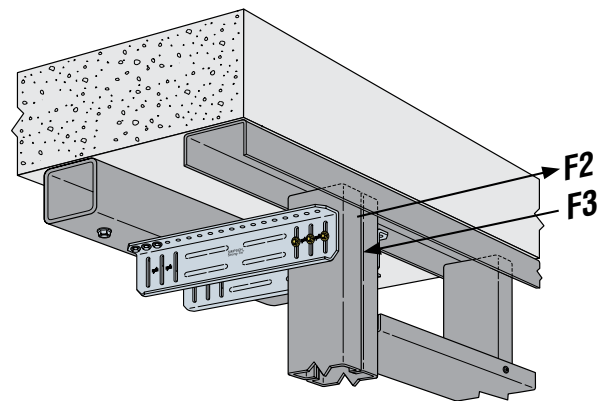

SSB3.518 Installation to Reinforce a Window/Door Jamb with Slip Track

SSB Bypass Framing Slide-Clip Strut Connector

SSB Allowable Connector Loads (lbs.)

Model No.	Connector Material Thickness mil (ga.)	No. of #14 Shouldered Screws	Stud Thickness					
			33 mil (20 ga.)		43 mil (18 ga.)		54 mil (16 ga.)	
			F2	F3	F2	F3	F2	F3
SSB3.518	54 (16)	2 ²	520	520	690	690	1075	960
		3	815	815	1030	1080	1335	1225

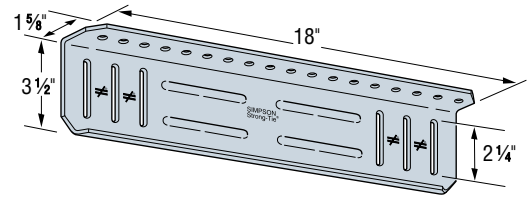

SSB

- For additional important information, see General Notes for Allowable Connector Load Tables on page 3.
- When the SSB connector is used with 2 shouldered screws, the screws may be installed in any 2 slots.
- Allowable loads are based on clips installed with (3) #12-14 screws in the anchor leg. For other anchorage installations, the capacity of the connection system will be the minimum of the tabulated value and the allowable load from the SSB Allowable Anchorage Loads table below.

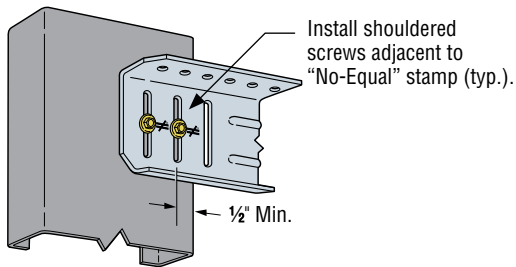

SSB Installation with 2 Shouldered Screws

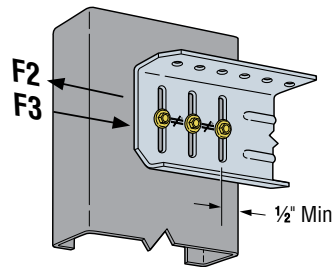

SSB Installation with 3 Shouldered Screws

SSB Allowable Anchorage Loads (lbs.)

Anchorage Type	No. of Anchors	Allowable Loads F2 and F3
#12-14 Self-Drilling Screws	2	1250
	3	1335
Simpson Strong-Tie® 0.145" PDPT or 0.157" PDPAT Powder-Actuated Fasteners	2	1320
	3	1335
Welded	Hard side: 2" Free side: 1"	1335

- For additional important information, see General Notes for Allowable Anchorage Load Tables on page 3.
- Allowable loads are for clip anchorage only. The capacity of the connection system will be the minimum of the tabulated value and the allowable load from the SSB Allowable Connector Loads table above.

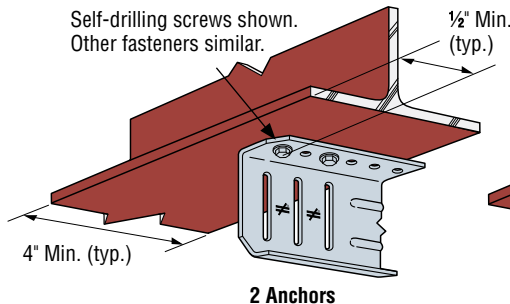

2 Anchors

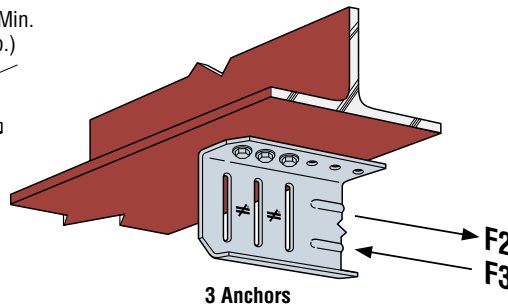

3 Anchors

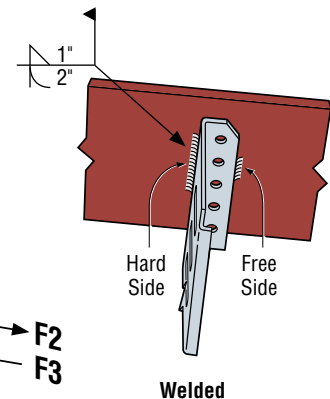

Welded

SSB Anchor Layout

FCB Bypass Framing Fixed-Clip Connector

The FCB clip is an economical, high-performance fixed-clip connector that can be used for a variety of framing applications. It is rated for tension, compression and shear loads and offers the Designer the flexibility of specifying different screw and anchorage patterns that conform to desired load levels.

FEATURES:

- Rated for tension, compression and shear loads
- Provides design flexibility with varying screw and anchorage patterns that achieve different load levels
- Strategically placed stiffeners, embossments and anchor holes maximize connector performance

MATERIAL: 54 mil (16 ga.)

FINISH: Galvanized (G90)

INSTALLATION:

- Use the specified type and number of anchors.
- Use the specified number of #12 self-drilling screws to CFS framing.

CODES: IAPMO ES ER-238

Ordering Information:

FCB43.5-R25, FCB45.5-R25, FCB47.5-R25, FCB49.5-R25, and FCB411.5-R25 contain:

- Box of 25 connectors (screws not included)

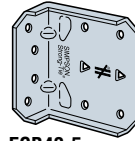

FCB43.5

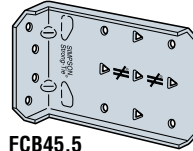

FCB45.5

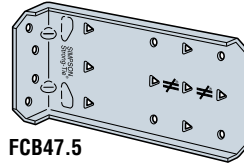

FCB47.5

U.S. Patent Pending

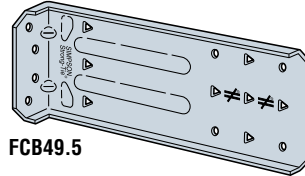

FCB49.5

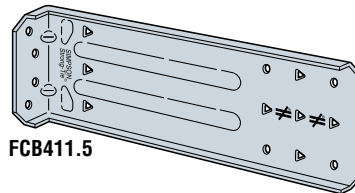

FCB411.5

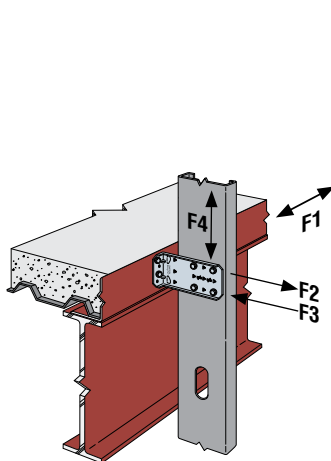

Typical FCB Installation at Bypass Framing

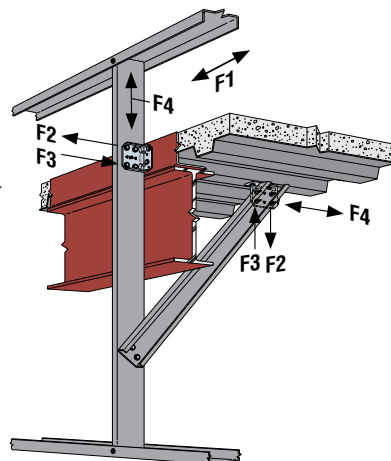

Typical FCB Installation at Sprandrel Studs and Kickers

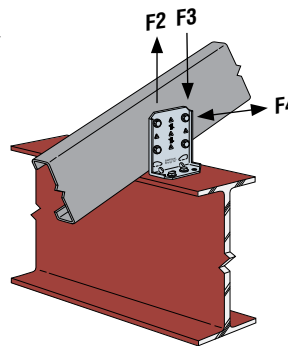

Typical FCB Installation for Roof Rafters

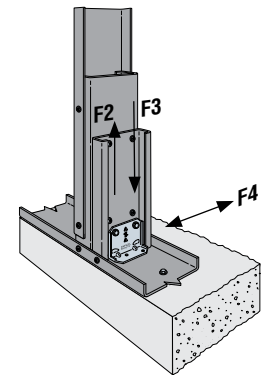

Typical FCB Installation at the Base of a 6" Jamb Stud

FCB Bypass Framing Fixed-Clip Connector

FCB Allowable Connector Loads (lbs.)

Model No.	Connector Material Thickness mil (ga.)	L (in.)	Min./Max.	No. of #12-14 Self-Drilling Screws	Stud Thickness											
					33 mil (20 ga.)				43 mil (18 ga.)				54 mil (16 ga.)			
					F1 ^{5,6}	F2 ⁴	F3 ⁴	F4 ⁴	F1 ^{5,6}	F2 ⁴	F3 ⁴	F4 ⁴	F1 ^{5,6}	F2 ⁴	F3 ⁴	F4 ⁴
FCB43.5	54 (16)	3½	Min.	4	135	755	755	755	205	1105	975	1120	235	1250	975	1490
			Max.	6	205	1100	1130	1130	205	1105	1260	1455	235	1250	1735	1910
FCB45.5	54 (16)	5½	Min.	4	120	755	755	755	175	1105	975	945	175	1105	975	1325
			Max.	9	155	1100	1260	1180	175	1105	1260	1485	175	1105	1735	1925
FCB47.5	54 (16)	7½	Min.	4	90	755	755	220	90	1105	945	330	90	1105	945	365
			Max.	12	205	1100	1260	705	235	1105	1260	1050	235	1105	1735	1445
FCB49.5	54 (16)	9½	Min.	4	60	755	755	170	60	1105	945	255	60	1105	945	365
			Max.	12	205	1100	1260	750	235	1105	1260	1115	235	1105	1735	1200
FCB411.5	54 (16)	11½	Min.	4	45	755	755	140	45	1105	920	205	45	1105	920	365
			Max.	12	205	1100	1260	795	235	1105	1260	860	235	1105	1735	860

- For additional important information, see General Notes for Allowable Connector Load Tables on page 3.
- Allowable loads for #12-14 self-drilling screws are based on a minimum Pss = 2485 lbs. and Pts = 2595 lbs.
- Min. fastener quantity and load values - fill all round holes; max. fastener quantity and load values - fill all round and triangular holes.
- Allowable loads are based on clip capacity only and do not consider anchorage. The capacity of the connection system will be the minimum of the tabulated value and the allowable load from the FCB Allowable Anchorage Loads table below.
- Anchorage to the supporting structure using welds or a minimum of (2) #12-14 self-drilling screws is required.
- Allowable loads are based on in-planes loads applied to the stud fasteners that are nearest the support with complete rotational restraint at the studs. For a more extensive treatment of in-plane loads please refer to Simpson Strong-Tie Engineering Letter L-CF-CWCF1DIR14.

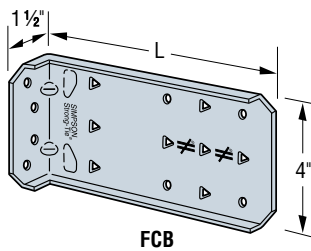

FCB

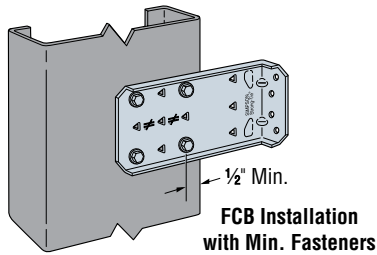

FCB Installation with Min. Fasteners

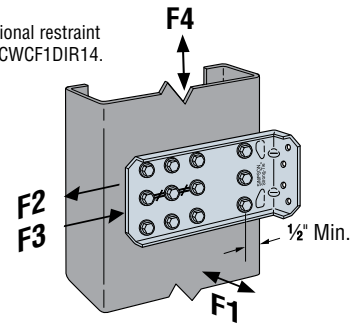

FCB Installation with Max. Fasteners

FCB Allowable Anchorage Loads (lbs.)

Anchorage Type	No. of Anchors	Allowable Loads (lbs.)									
		F2 and F3	F4								
			FCB43.5		FCB45.5		FCB47.5		FCB49.5		FCB411.5
Min./Max.	Min./Max.	Min.	Max.	Min.	Max.	Min.	Max.	Min.	Max.		
#12-14 Self-Drilling Screws	2	795	625	410	255	445	185	265	120	190	
	3	1120	690	450	280	490	200	295	135	210	
	4	1585	1255	820	365	890	350	535	275	380	
Simpson Strong-Tie® 0.145" PDPT or 0.157" PDPAT Powder-Actuated Fasteners	2	280	410	265	165	290	120	175	75	125	
	3	390	465	305	190	330	135	195	85	140	
	4	555	840	550	340	595	245	355	145	255	
¼"x1 ¼" Simpson Strong-Tie® Titen® Hex-Head Screws	2	380	415	270	165	295	120	175	215	125	
	3	445	470	310	190	335	140	200	100	145	
	4	510	645	420	260	455	190	275	280	195	
Welded	Hard side: 2"	1735	1910	1925	365	1445	365	1200	365	860	
	Free side: 1"										

- For additional important information, see General Notes for Allowable Anchorage Load Tables on page 3.
- Min. and max. refer to stud fasteners. See FCB Allowable Connector Loads table above.
- Allowable loads are for clip anchorage only. The capacity of the connection system will be the minimum of the tabulated value and the allowable load from the FCB Allowable Connector Loads table above.

Self-drilling screws shown. Other fasteners similar. ½" Min., for steel 1" Min. at concrete (typ.)

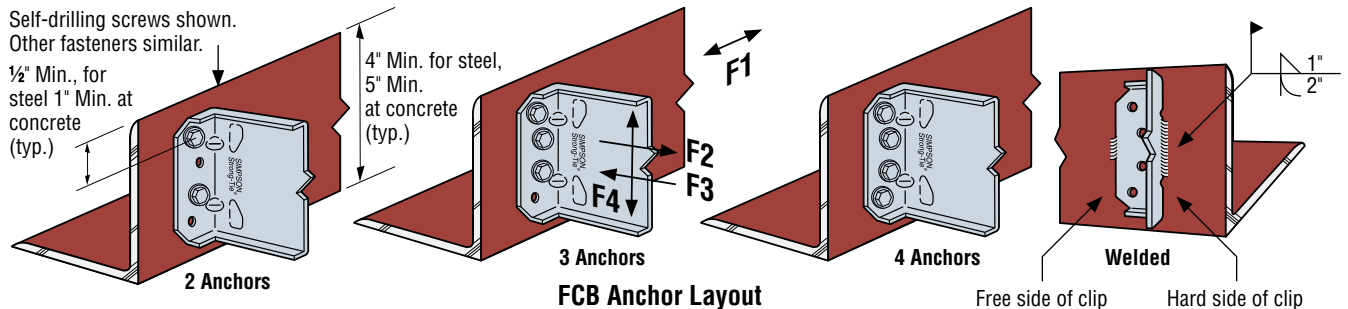

FCB Anchor Layout

Custom Clips and Connectors

Simpson Strong-Tie can make a variety of flat and bent steel clips and connectors for cold-formed steel framing. Most custom clips can be punched with different holes and slots.

MATERIAL: 229 mil (3 ga.) maximum, 43 mil (18 ga.) minimum mill-certified steel (carbon and type 316L stainless steel)

FINISH: Galvanized, Simpson Strong-Tie® gray paint. Contact Simpson Strong-Tie for availability.

TO OBTAIN A QUOTE:

- Supply a CAD drawing in .dwg or .dxf format complete with all dimensions, hole diameter and centerline locations, bend angles, steel strength (min. F_y and F_u), thickness (mils and/or ga.) and finish: (galvanized to G90, G185) or Simpson Strong-Tie gray paint (specify).
- Total shape and size up to a maximum of 48" x 48" (approx. $\frac{1}{16}$ " tolerance).
- Simpson Strong-Tie does not provide product engineering or load values for special-order custom clips and connectors.
- Contact Simpson Strong-Tie for pricing information.
- For additional information please refer to Important Information and General Notes in the Simpson Strong-Tie®, *Cold-Formed Steel Connectors for Residential and Mid-Rise Construction* catalog.

SPECIFICATION EXAMPLE:

QUANTITY: XX pieces

DIMENSIONS: Per the attached CAD drawing (.dwg or .dxf format)

Drawing must be fully dimensioned, including:

- Overall dimensions
- Leg dimensions
- Bend angles (if required)
- Hole/slot sizes and centerlines (if required)

MATERIAL SPECIFICATION: (Contact Simpson Strong-Tie for availability)

THICKNESS: 54 mil (16 ga.)

STRENGTH: Min. Yield Strength (F_y) = 33 ksi,
Min. Tensile Strength (F_u) = 45 ksi

FINISH: Galvanized G90

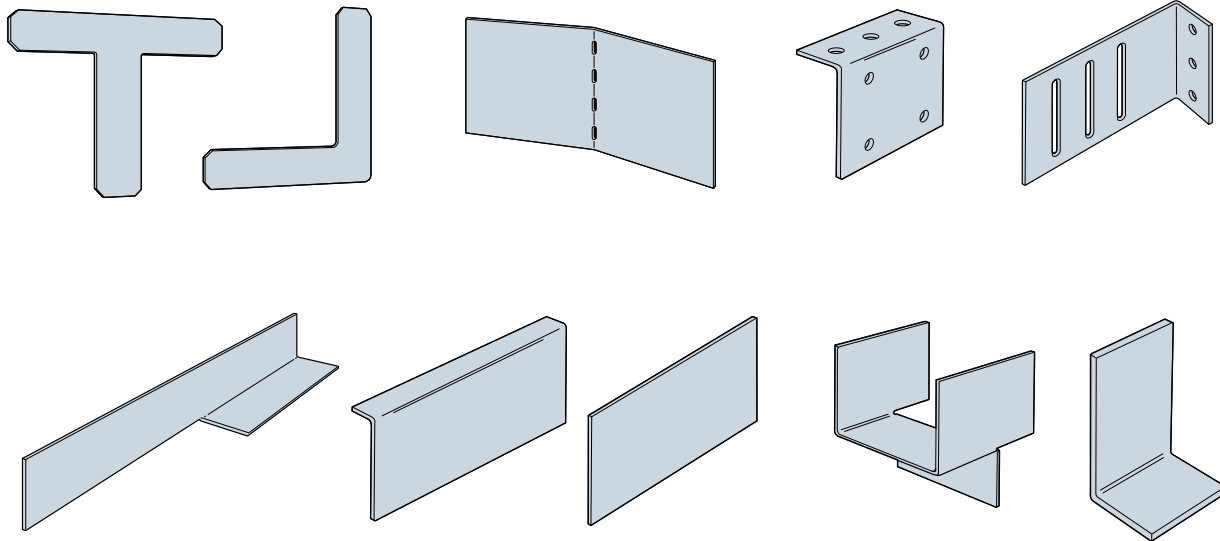

This flier is effective until December 31, 2016, and reflects information available as of August 1, 2014. This information is updated periodically and should not be relied upon after December 31, 2016; contact Simpson Strong-Tie for current information and limited warranty or see www.strongtie.com.

©2014 Simpson Strong-Tie Company Inc. • P.O. Box 10789, Pleasanton, CA 94588

F-CF-CWC14 8/14 exp. 12/16

800-999-5099
www.strongtie.com