



Elevate Your Composite-to-Steel Installations

Solutions for an Efficient
Steel-Framed Deck

(800) 999-5099
www.strongtie.com

Deck-Drive™ DCSD COMPOSITE-TO-STEEL Screw

Engineered for faster, cleaner installations

The Deck-Drive™ DCSD Composite-to-Steel screw has been specially designed to fasten composite decking to steel and aluminum deck-frame systems using the Simpson Strong-Tie® Quik Drive® system. Now decking can be fastened from a standing position with an auto-feed system that speeds installation and provides a clean, finished appearance.

- Engineered for performance, the DCSD's patent-pending screw shaft and point drive easily through both composite decking and double 14 ga. steel box beam without pre-drilling
- The Quik Drive® PRO300S auto-feed screw driving system holds the screw securely as it drills through metal joists for a more consistent installation.

Features

#3 drill tip provides fast self-drilling

Unique fluted pilot point clears steel material

Helical cutters for easier tapping

Cap-head prevents mushrooming and decking material from rising up above the deck level, creating a smoother, clean-looking installation

Quik Guard® coating provides corrosion resistance for exterior use

Inverted upper threads clear excess decking material to ensure the screw is seated properly and consistently



#2 square driver bit included (replacement driver bit – BIT2SU)

Color matched to blend with most major composite decking products



Length (in.)	Size	Coating	Color	Compatible QD systems	Quik Drive part # (1000 ct.)	Use with Trex® Color (Colors will also match other major composite decking manufacturers)
2 3/8"	#10	Quik Guard	Brown 01	PR0300S, PR0250	DCSD238SBR01	Vintage Lantern, Woodland
2 3/8"	#10	Quik Guard	Tan 01	PR0300S, PR0250	DCSD238STN01	Tree House, Saddle, Spiced Rum, Havana Gold, Barrel
2 3/8"	#10	Quik Guard	Gray 01	PR0300S, PR0250	DCSD238SGR01	Gravel Path
2 3/8"	#10	Quik Guard	Red 01	PR0300S, PR0250	DCSD238SRD01	Lava Rock, FirePit
2 3/8"	#10	Quik Guard	Gray 04	PR0300S, PR0250	DCSD238SGR04	Flint, Winchester Grey
2 3/8"	#10	Quik Guard	Tan 02	PR0300S, PR0250	DCSD238STN02	Rope Swing

Screw design is patent pending.
Approved fastener (by Trex) for Trex® Elevations™.

Quik Drive™ PRO300S Decking System

Save Time and Money with Faster Installation Speeds and Consistent Performance

The Quik Drive® PRO300S Decking system is ideal for driving collated Deck-Drive™ DCSD Composite-to-Steel screws. Stand-up driving allows for improved labor-savings with less user fatigue and better consistency.

The PRO300S Decking System Includes:

- PRO300S Decking attachment (also sold separately)
- Extension for stand-up driving
- Decking nose clip for consistent screw placement
- Quiver for keeping screws at your fingertips
- Sturdy tool case
- Choice of Makita®, DeWalt® or Milwaukee® screwdriver motors
- Lifetime warranty
(see strongtie.com/warranty for more information)

DeWalt, Makita and Milwaukee are trademarks of their respective companies.



Quik Drive® PRO300S Decking System Options

System Motor Options	Model No.
DeWalt® 2500 rpm screwdriver motor	PRO300SD25K
Makita® 2500 rpm screwdriver motor	PRO300SM25K
Milwaukee® 2500 rpm screwdriver motor	PRO300SMW25K

Strong-Drive® XE EXTERIOR STRUCTURAL METAL Screw

Fasten Simpson Strong-Tie® Connectors to Trex® Elevations™ Framing

The Strong-Drive® XE Exterior Structural Metal screw is the only fastener load-rated for Simpson Strong-Tie® connectors used with Trex® Elevations™ steel deck framing. This new #10 x ¾", hex-head, Quik Guard®-coated screw has undergone a dual-hardness heat treatment not utilized in standard self-drilling screws. The tip is hardened to facilitate drilling efficiency. The load-bearing, threaded shank is kept at a lower hardness to ensure that it is ductile and less prone to failure due to hydrogen embrittlement.

Features

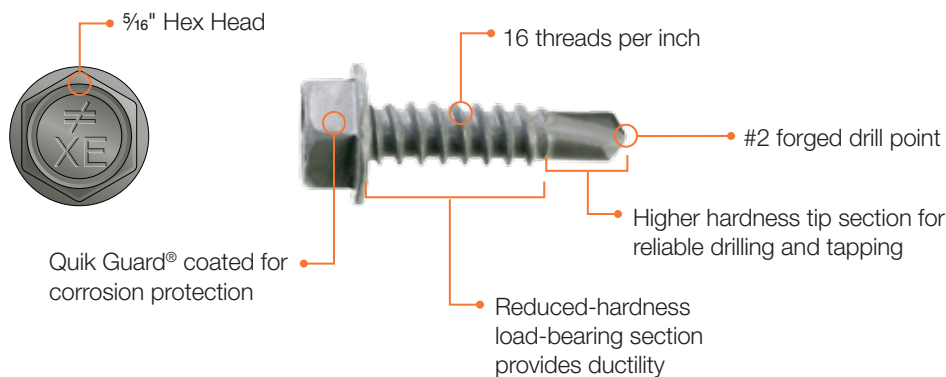

- Dual-hardened heat treatment provides resistance to hydrogen-assisted failure
- Meets ASTM C1513 drill-time performance
- Load-rated in LS70Z and L70Z

Quik Guard® Coating

Length (in.)	Screw Size/ Nail Gauge	Shank Dia. (in.)	Head Dia. (in.)	Drive	Head Type	Threads Per Inch	Point	Point Size	Material/ Coating	Package Size	Model No.
¾	10	0.19	0.4	5/16" Hex	Hex Washer Head	16	#2 Drill Point	2	Quik Guard® Coating	100	XEQ34B1016C
¾	10	0.19	0.4	5/16" Hex	Hex Washer Head	16	#2 Drill Point	2	Quik Guard® Coating	1000	XEQ34B1016M

Simpson Strong-Tie Connectors Approved by Trex for Trex Elevations Steel Deck Framing

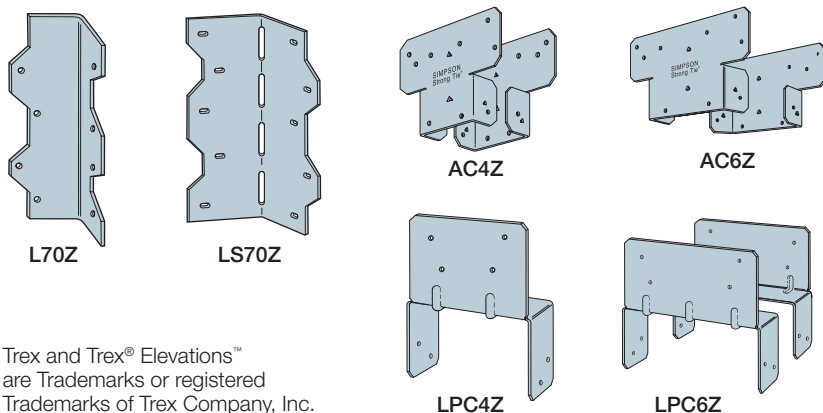

Trex and Trex® Elevations™ are Trademarks or registered Trademarks of Trex Company, Inc.



This filer is effective until December 31, 2017, and reflects information available as of June 1, 2015. This information is updated periodically and should not be relied upon after December 31, 2017 contact Simpson Strong-Tie for current information and limited warranty or see www.strongtie.com.